



## S & V-series Flow Monitor

### Instructions for ATEX applications





## Contents

Instructions .....	1
1. Scope .....	3
2. Device description.....	3
2.1. All different models are according to codification table below. ....	5
2.2. Different S Exd and V Exd material and housing types: .....	6
3. Installation and operating conditions.....	7
3.1. Equipment approval category .....	7
3.2. Type of protection.....	7
3.3. Gas Group.....	7
3.4. Temperature Class .....	7
3.5. Ex db microswitch.....	7
3.5.1. Maximum switching capacity .....	7
3.5.2. Electrical connection.....	8
4. ATEX labeling .....	8
5. General notes.....	8
6. Contact.....	9

## 1. Scope

These instructions are applicable only to devices that have application options for use in hazardous areas (intrinsically safe and explosion-proof devices). For all other data, use the Manual Eletta Flow Monitor S & V-series. If you do not have these documents, please contact the nearest sales office or download them from the [www.eletta.com](http://www.eletta.com)

### *Information!*

*The information in this ATEX instructions only contains the data applicable to explosion protection. The technical data in the installation and operating manual for the non-Ex version shall be valid in its current version, they are not rendered invalid or are replaced by this ATEX supplement.*

## 2. Device description

V-series flow switches and S-series flow indicators/switches operate on the pressure differential principle. They work on liquids. The S series model is intended to indicate the instantaneous flow in the pipe where it is installed and to trigger two independent electrical contacts, microswitch type, for two given flow thresholds. The V series model has no visual indication, it is intended to trigger an electrical microswitch for a given flow rate threshold in the pipe where it is installed.

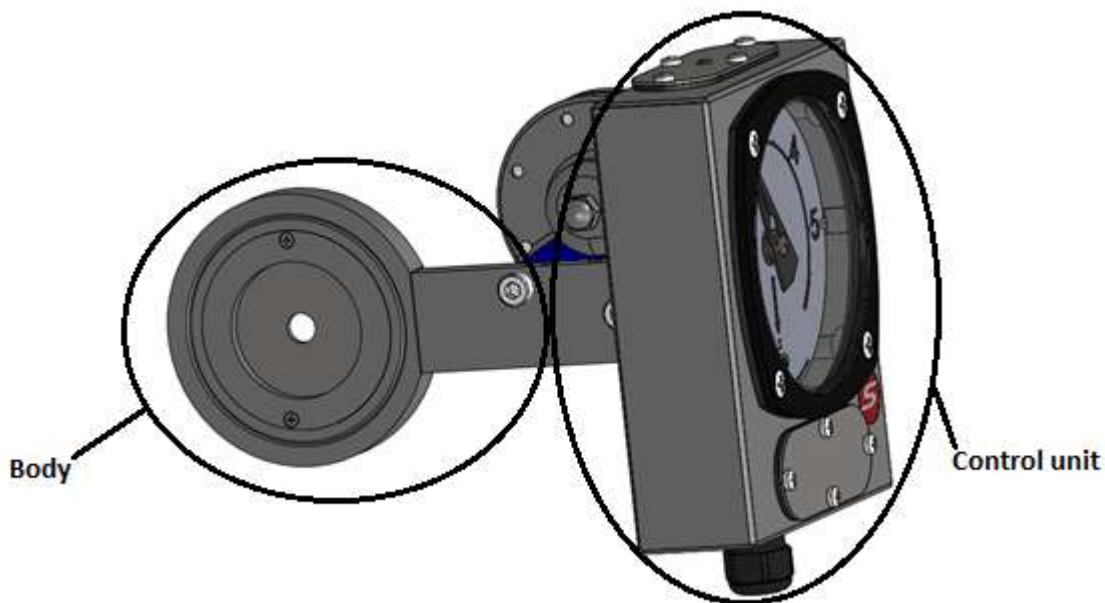

The S & V-series consist of 2 main parts, a body which contains a calibrated orifice plate and a control unit. The passage of the fluid inside the calibrated orifice located in the body creates a differential pressure. This differential pressure is proportional to the flow. The fluid fills the pressure tapping channels and the parts on either side of the diaphragm in the diaphragm chamber. The pressure differential is therefore transmitted on either side of the membrane. The movement of the membrane is a function of the differential pressure and therefore of the flow rate. The membrane will transmit its movement to a lever to which it is mechanically connected. The lever seals between the diaphragm chamber, which is pressurized from the inside of the pipe, and the inner part of the housing, which is exposed to the atmosphere. The lever transmits

the movement of the membrane to change the state of the microswitch contact for a given flow rate.

The sketch below shows the internal parts of the V series:

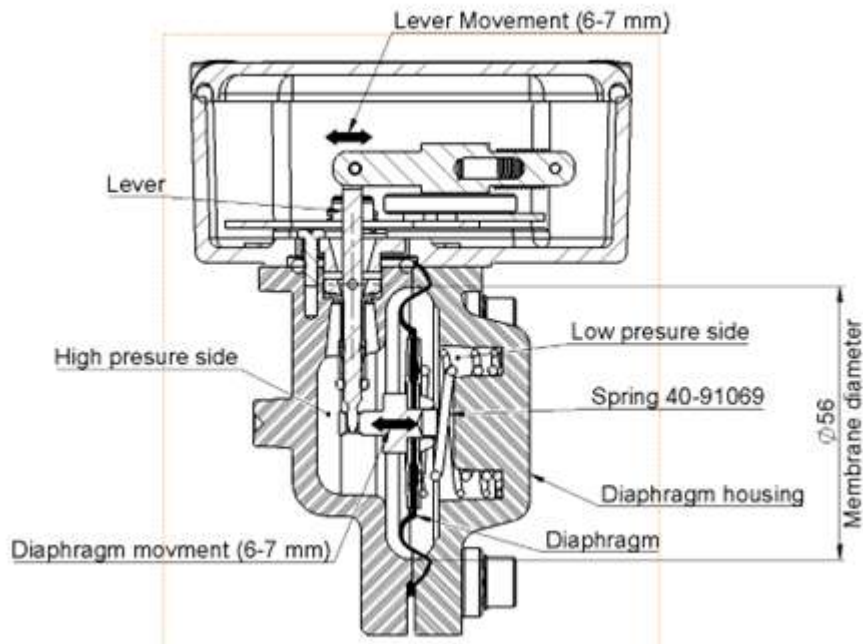

In the case of the S series, the lever activates a clockwork mechanism which will transform the translational movement of the lever into a rotational movement. A pointer is fitted to the clockwork mechanism indicates the instantaneous flow rate on the graduated dial. The lever also drives the change of state of the two microswitch contacts for the given flow rates. The V series works the same way but without pointer indicator.

V-series flow switches and S-series flow indicators/switches are installed on pipes either between flanges or with threaded connections.

*Information!*

*In the case of the ATEX version of S and V series, the mechanical part of the flow sensor is associated to one or two already ATEX approved microswitch.*



2.1. All different models are according to codification table below.

ATEX template for range details			
<b>Type</b>			
S Exd	Flow indicator with 2 microswitch		
V Exd	Flow switch with 1 microswitch		
<b>Housing material</b>			
-	Aluminum alloy housing		
SS	Stainless steel housing		
SS Cast	Cast stainless steel housing		
<b>Body</b>			
FA	Cast iron and brass Wafer mounting		
FSS	Stainless steel Wafer mounting		
GL	Brass Threaded connection		
GSS	Stainless steel Threaded connection		
DN - Normal diameter			
1/2"	15		
3/4"	20		
1"	25		
1 1/2"	40		
1 1/4"	32		
2"	50		
2 1/2"	65		
3"	80		
4"	100		
5"	125		

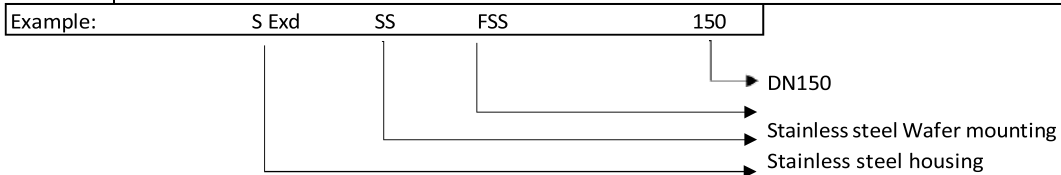

2.2. Different S Exd and V Exd material and housing types:

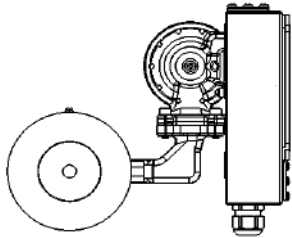

**S Exd SS FA**

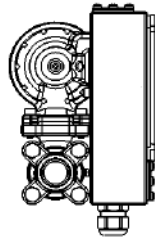

**S Exd SS GL**

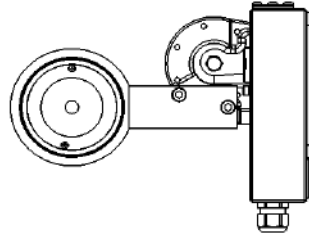

**S Exd SS FSS**

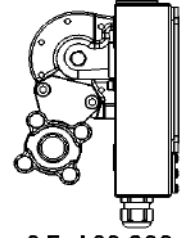

**S Exd SS GSS**

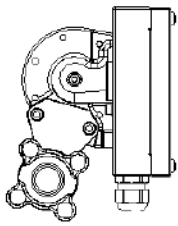

**V Exd SS GSS**

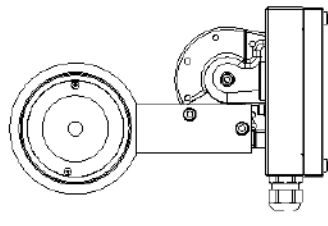

**V Exd SSFGSS**

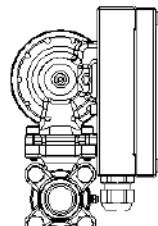

**V Exd SS GL**

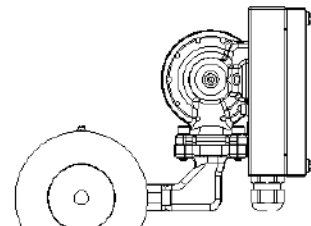

**V Exd SS FA**

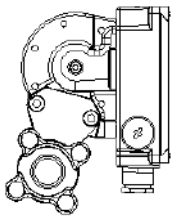

**V Exd - GSS**

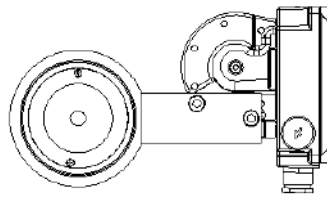

**V Exd - FSS**

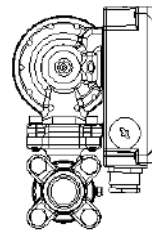

**V Exd - GL**

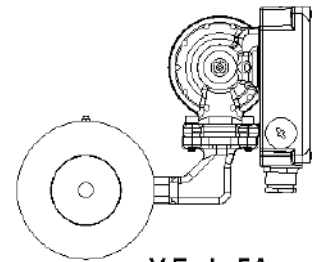

**V Exd - FA**

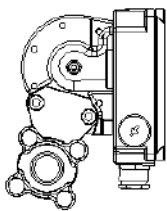

**V Exd SS Cast GSS**

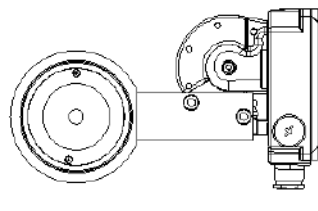

**V Exd SS Cast FSS**

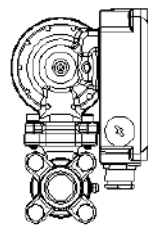

**V Exd SS Cast GL**

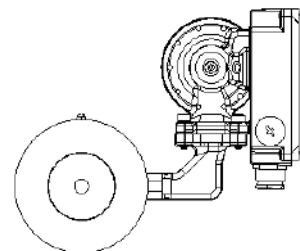

**V Exd SS Cast FA**



### 3. Installation and operating conditions

#### 3.1. Equipment approval category

Assembly is designed to be installed inside zone 1, construction category is II 2G (For surface = II, Instrument category = 2, for gas atmosphere = G)

#### 3.2. Type of protection

The design of assembly is mechanical explosion proofed h d.

#### 3.3. Gas Group

Assembly is designed to be installed into gas atmosphere, for gas group IIC.

#### 3.4. Temperature Class

Maximum temperature which can be reached by flow sensor body is the fluid temperature which is going through. Temperature class will consequently be according to max fluid temperature.

Temperature classes are according below table.

Reminder regarding temperature class values (temperature class value is the maximum surface temperature which can be reached by the flow sensor):

T1 : 450°C    T2 : 300°C    T3 : 200°C    T4 : 135°C    T5 : 100°C    T6 : 85°C

Ambient Temperature	Fluid Temperature	Temperature Class
Tamb < 75°C	T fluid < 85°C	T6
Tamb < 75°C	T fluid < 100°C	T5
Tamb < 75°C	T fluid < 135°C	T4
Tamb < 75°C	T fluid < 200°C	T3

#### 3.5. Ex db microswitch

The assembly including a SPDT ATEX II 2G db IIC T6, T5 Gb switches. Switches are with 3-meter connection cable. Cable cross section area is 0.75 mm<sup>2</sup>. Cables will have to be connected into junction box suitable for ATEX area. Recommended models can be advised on request. Do not open junction box while device is energized.

##### 3.5.1. Maximum switching capacity

<b>Switching capacity with AC</b>		
	Ohmic load	Inductive load
250 V	5 A	5 A
30 V	5 A	5 A
<b>Switching capacity with DC</b>		
	Ohmic load	Inductive load
250 V	0.25 A	0.03 A
125 V	0.5 A	0.06 A
75 V	1 A	1 A
30 V	5 A	5 A

### 3.5.2. Electrical connection

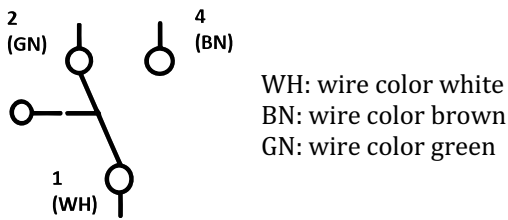

## 4. ATEX labeling

II 2G Ex h d IIC T6(85°C) – Gb

**Labeling example:**

**Equipment group, Safety category and Atmosphere** II 2G

**Type of protection** h d

**Gas group** IIC

**Temperature class** T6-T3

**Equipment protection level** Gb

## 5. General notes

The ATEX version of S and V series is considered as a mechanical instrument because it is an assembly between a totally mechanical instrument and ATEX certified microswitch. ATEX directive 2014/34/EU will then be applicable to this assembly. A risk analysis has been performed for the flow sensor. The assembly is CE marked. Technical file with risk analysis deposited at LCIE, notified Body number 0081, LCIE file N° 17120470-783928.

Nonelectrical component:

Flow sensor according to the codification table.

Electrical component:

Microswitch with connection cable. Marked with II 2G Ex db IIC T6, T5 Gb.

Ignition risk evaluation of the flows sensors has been carried out according EN ISO 80073-36 for non-electrical equipment for explosive atmosphere. According to assessment table, it appears there is no ignition risk from the flow sensor. Flow sensor is fitted with already ATEX approved microswitch. Association the 2 components is therefore not bringing any ignition risk.

S and V flow indicator switch ATEX version are compliant with EPL Gb and can be marked:

II 2G Ex h d IIC T6(85°C)... T3(200°C) – Gb.

Make sure of the correct grounding of the instruments.





## 6. Contact

Eletta Flow AB  
P.O. Box 5084  
SE-141 05 Kungens Kurva  
SWEDEN

E-mail [info@eletta.com](mailto:info@eletta.com)  
[www.eletta.com](http://www.eletta.com)  
Phone + 46 8 603 07 70 Switchboard  
+ 46 8 603 07 80 Orders and Inquires