

Weight and Dimensions

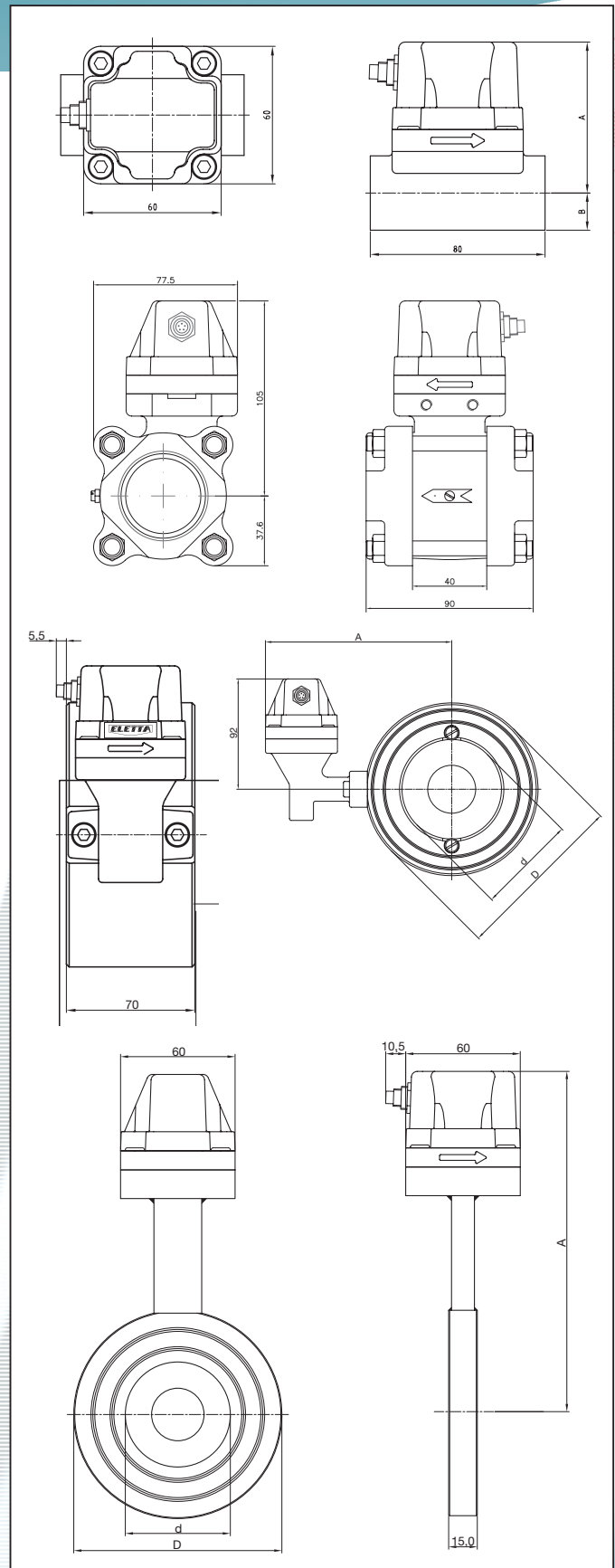

Type G, thread	d	A (mm)	B (mm)	Weight (kg)*
-G15	1/2"	66	14	0,8
-G20	3/4"	69	17	0,9
-G25	1"	73	21	1,0
Type GL, thread	d	A (mm)	B (mm)	Weight (kg)
-GL40	1 1/2"	105	38	2,3
Type FA, flange DIN-PN16	d (mm)	D (mm)	A (mm)	Weight (kg)*
-FA15 (1/2")	16	53	108	2,6
-FA20 (3/4")	22	63	112	3,0
-FA25 (1")	30	73	118	3,2
-FA32 (1 1/4")	39	84	124	3,7
-FA40 (1 1/2")	43	94	129	4,4
-FA50 (2")	55	109	137	4,5
-FA65 (2 1/2")	70	129	147	5,6
-FA80 (3")	82	144	155	6,4
-FA100 (4")	107	164	165	6,8
-FA125 (5")	132	194	181	8,9
-FA150 (6")	160	219	193	9,8
-FA200 (8")	207	274	220	13,7
-FA250 (10")	260	330	248	17,3
-FA300 (12")	310	385	277	20,0
-FA350 (14")	340	445	307	30,6
-FA400 (16")	390	498	333	39,5
Type F..SS, flange DIN-PN16	d (mm)	D (mm)	A (mm)	Weight (kg)*
-F15SS (1/2")	17	53	143	1,6
-F20SS (3/4")	22	63	149	1,7
-F25SS (1")	29	73	154	1,8
-F32SS (1 1/4")	39	84	160	1,9
-F40SS (1 1/2")	43	94	165	2,0
-F50SS (2")	55	109	173	2,2
-F65SS (2 1/2")	70	129	183	2,5
-F80SS (3")	82	144	191	2,6
-F100SS (4")	107	164	201	3,0
-F125SS (5")	132	194	216	3,6
-F150SS (6")	160	219	239	4,1
-F200SS (8")	207	274	266	5,5
-F250SS (10")	260	330	295	7,5



*Approximate weight

For F..SS are other standards of pressure available as option.